

Catálogos

Levante Sistemas de Automatización y Control S.L.



LSA Control S.L. - Bosch Rexroth Sales Partner
Ronda Narciso Monturiol y Estarriol, 7-9
Edificio TecnoParQ Planta 1ª Derecha, Oficina 14
(Parque Tecnológico de Paterna)
46980 Paterna (Valencia)

Telf. (+34) 960 62 43 01

comercial@lsa-control.com

www.lsa-control.com

www.boschrexroth.es



www.lsa-control.com

Distribuidor oficial Bosch Rexroth, Indramat, Bosch y Aventics.

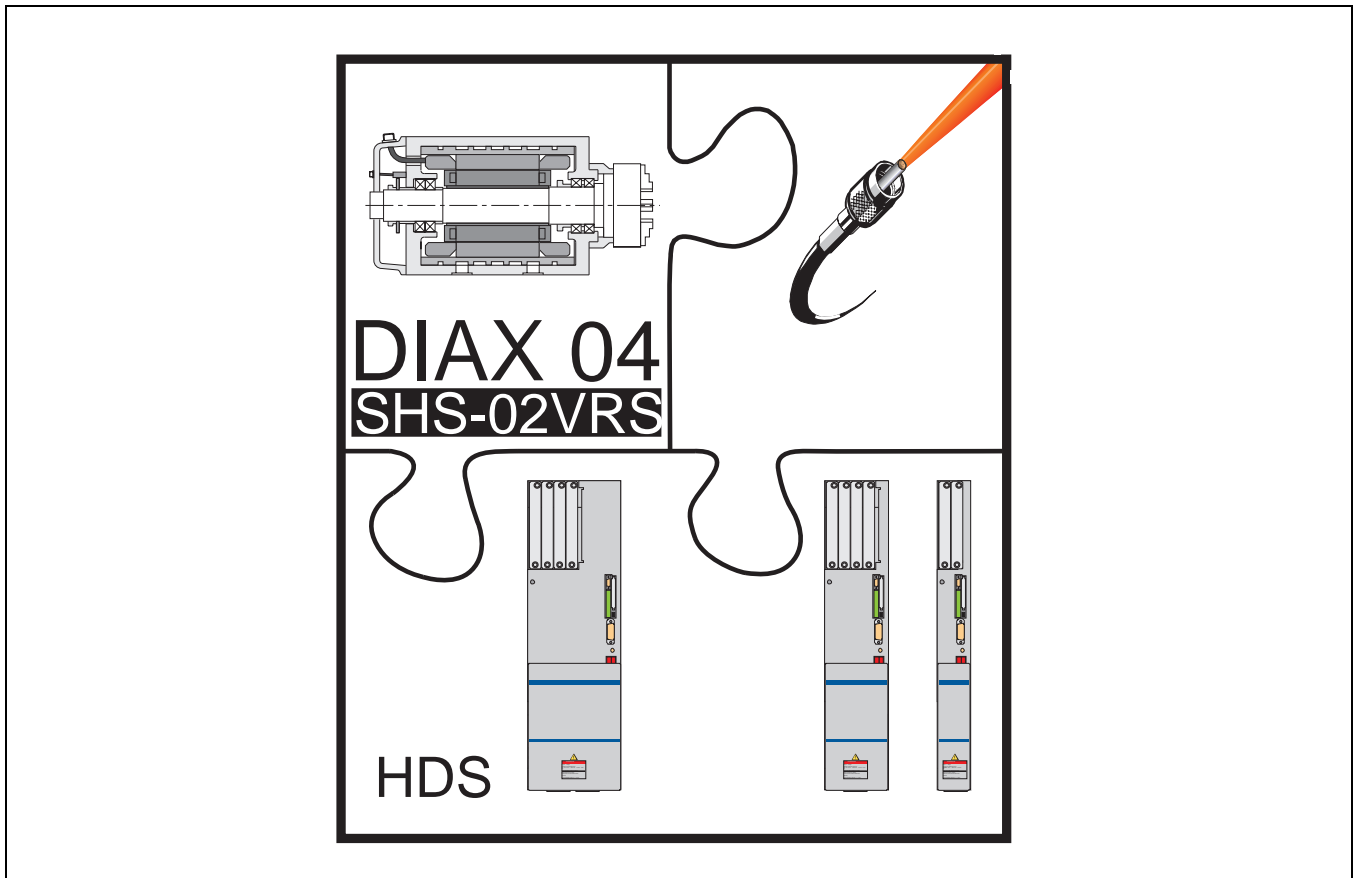

DIAX04 Main Spindle Drives

Drive Configuration

DOK-DIAX04-SHS/AHS****-INF1-EN-P



278054



Title	DIAX04 Main Spindle Drives								
Type of documentation	Drive configuration								
Document code	DOK-DIAX04-SHS/AHS****-INF1-EN-P								
Internal file reference	<ul style="list-style-type: none"> • Mapped 62-02V-DE / Register 7 • 209-0074-4311-00 								
The purpose of this documentation	<p>This documentation helps in determining a configured drive controller of the DIAX04 machine series based on</p> <ul style="list-style-type: none"> • motor type • selecting the motor / motor feedback combination and • selecting the desired functionalities of the drive controllers <p>It also offers an overview of the basic functions available as well as possible optional functions.</p>								
Editing sequence	<table border="1"> <thead> <tr> <th>Document identification of previous editions</th> <th>Release date</th> <th>Comments</th> </tr> </thead> <tbody> <tr> <td>DOK-DIAX04-SHS/AHS****-INF1-EN-P</td> <td>11.97</td> <td>1st edition</td> </tr> </tbody> </table>			Document identification of previous editions	Release date	Comments	DOK-DIAX04-SHS/AHS****-INF1-EN-P	11.97	1 st edition
Document identification of previous editions	Release date	Comments							
DOK-DIAX04-SHS/AHS****-INF1-EN-P	11.97	1 st edition							
Copyright	<p>© INDRAMAT GmbH, 1997</p> <p>Copying this document and giving it to others and the use and communication of the contents hereof without express authority are forbidden. Offenders are liable for the payment of damages. All rights reserved in the event of the grant of the registration of a utility model or design. (DIN 34-1)</p>								
Published by	<p>INDRAMAT GmbH • Bgm.-Dr.-Nebel-Str. 2 • D-97816 Lohr a. Main Telefon 09352/40-0 • Tx 689421 • Fax 09352/40-4885 Abt. ENH/ENA (VS/MR)</p>								
Validity	<p>All rights reserved for changes in documentation and delivery of the product.</p>								

Contents

1 Determining Drive Configuration	1-1
1.1 Definition of Terms	1-1
1.2 Procedure.....	1-3
Diagram: Determining the Hardware Configuration Designations	1-4
2 Determining the Motor/Controller Combinations	2-1
2.1 Selection Lists.....	2-1
3 Selecting Motor and Motor Feedback Combinations	3-1
3.1 Possible Motor/Motor Feedback Combinations	3-1
3.2 Connections	3-2
DSF/RSF	3-2
Sine Encoder.....	3-2
Gear/wheel Encoder.....	3-3
Gear/wheel encoder (Lenord & Bauer, Woelke, VS-Sensorik, Siemens)	3-3
4 Selecting the Functions - Determining Configuration Designations	4-1
4.1 Basic Functions.....	4-1
4.2 Selecting Additional Functions.....	4-2
Motor Feedback: DSF / RSF.....	4-3
Motor Feedback: Sine Encoder.....	4-5
Motor Encoder Interface: Gear/ Wheel Encoder made by INDRAMAT	4-6
Motor Feedback: Gear/Wheel Encoder made by Lenord & Bauer, Woelke, VS-Sensorik, Siemens	4-7

1 Determining Drive Configuration

1.1 Definition of Terms

Digital drive controllers of the DIAX04 product line made by INDRAMAT are adapted to a wide variety of customer demands by outfitting them with different plug-in modules. This means that the drive controllers are equipped with slots which accommodate these modules.

Basic units

Digital drives not equipped with plug-in cards are defined as basic units. The following controllers are available:

- HDS04.1 4 slots for plug-in modules (U1...U4)
1 slot for software module (U5)
- HDS03.1 4 slots for plug-in modules (U1...U4)
1 slot for software module (U5)
- HDS02.1 3 slots for plug-in modules (U1...U3)
1 slot for software module (U5)
- HDD02.1 1 slot for plug-in module per axis (U1.1, U1.2)
1 slot for software module per axis (U5.1, U5.2)

Plug-In Modules

The following plug-in modules are available:

- command communications modules
- modules for the evaluation of position measuring systems and
- input/output modules to evaluate PLC signals or generate signals for the PLC

Command communications modules

Available as command communications modules are:

- SERCOS interface command communications modules
- analog interface command communications modules

The command communications modules are always in slot U1 of the drive controller.

Configured drive controller

A basic unit equipped with plug-in and software modules is defined as a configured drive controller.

Hardware configuration

Each hardware configuration is labelled with a letter/number combination, e.g., HS04-01-FW. Digital drive controllers come as configured drive controllers equipped as specified for the configuration.

The following figure shows the parts of a hardware configuration.

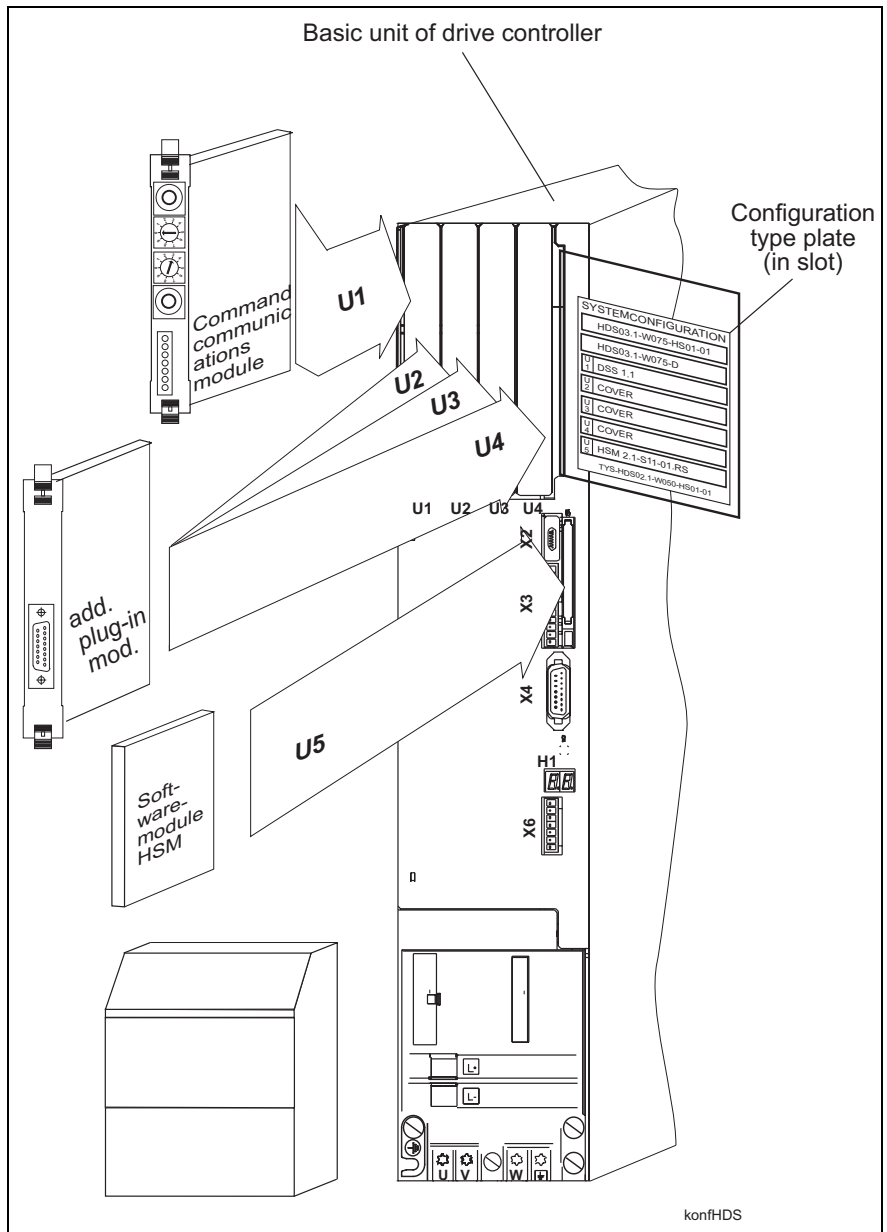

Fig. 1-1: The parts of a hardware configuration

1.2 Procedure

The following procedure is recommended for determining both the drive and hardware configurations of a DIAX04 drive controller:

1. Determine motor/controller combination:
 - determine velocity/torque requirements in terms of application
 - select motor/controller combination in the selection lists.

2. Determine hardware configuration designations:
 - select motor and motor feedback combination
 - select those functions wanted

 - determine configuration designation of the plug-in modules needed in terms of the functions to be performed.

Below please find a schematic diagram to help locate hardware configuration designations.

Diagram: Determining the Hardware Configuration Designations

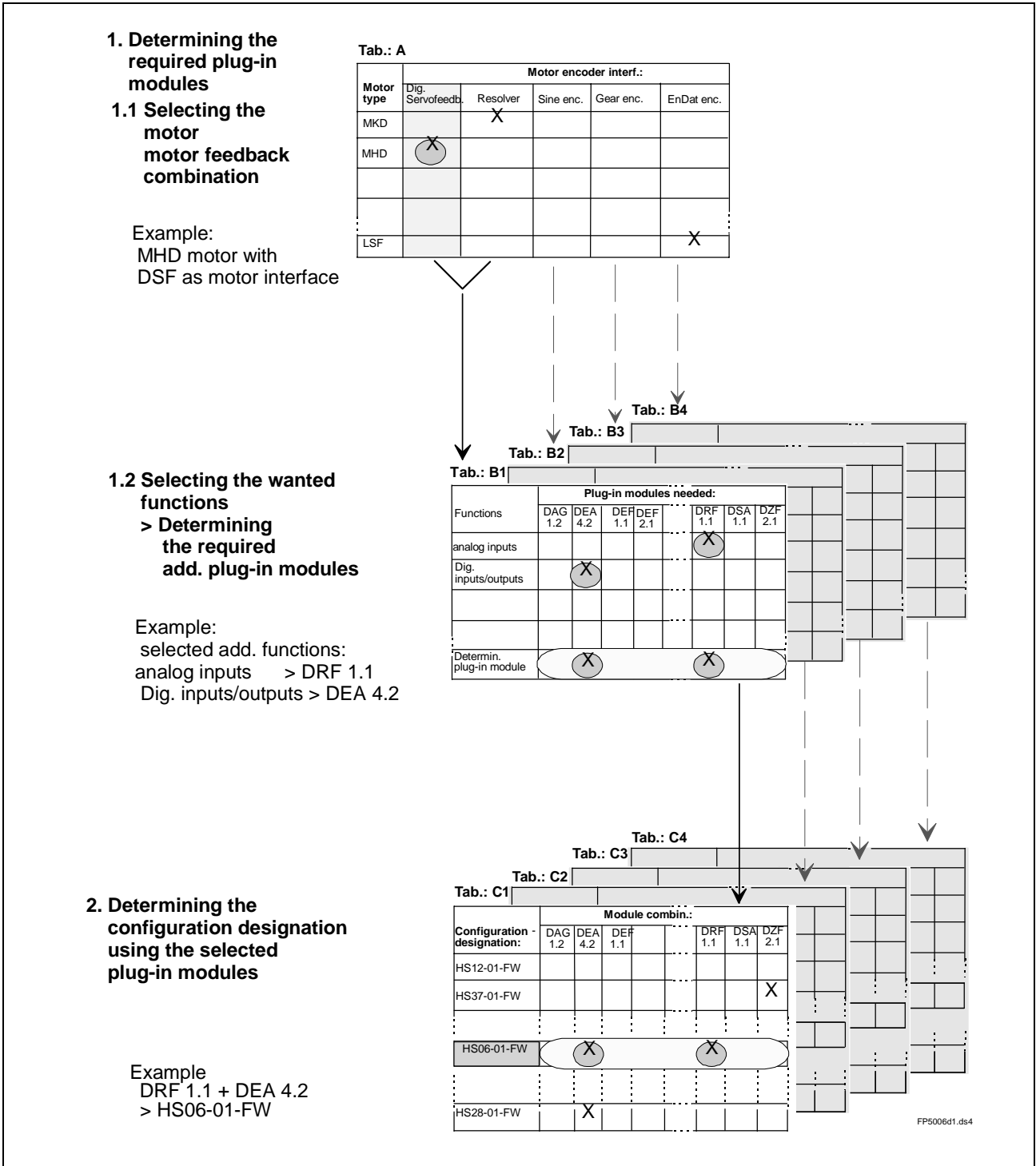

Fig. 1-2: Schematic diagram on determining the configuration designations

2 Determining the Motor/Controller Combinations

2.1 Selection Lists

Use the selection list to locate the desired motor/controller combination. Keep in mind the power requirements, torque and velocity requirements as well as any structural demands.

When determining the hardware configuration designation, the results obtained from the selection list are determinative for the **motor type that must be used**.

Notes

3 Selecting Motor and Motor Feedback Combinations

3.1 Possible Motor/Motor Feedback Combinations

The table below sets motor type to motor feedback type.

The motor feedback must be selected in terms of the motor type to which it has been allocated.

Tab A: Motor feedback types					
Motor	Digital servo feedback (1)	Resolver (2)	Sine encoder (3)	Gear/wheel encoder from INDRAMAT	Gear/wheel encoder 1V _{SS} (4)
MKD/MHD		X			
MHD	X				
2AD	X			X	
ADF	X			X	
1MB	X		X	X	X

Tab. 3-1: Allowable motor/motor feedback combinations

- (1) : singleturn or multiturn DSF
- (2) : resolver or multiturn resolver
- (3) : incremental sine encoder 1V_{SS}
- (4) : gear/wheel encoder 1V_{SS} (Lenord & Bauer, Woelke, VS-Sensorik, Siemens)

3.2 Connections

DSF/RSF

The motor feedback is connected at the controller's standard interface. This means that no additional plug-in cards are needed.

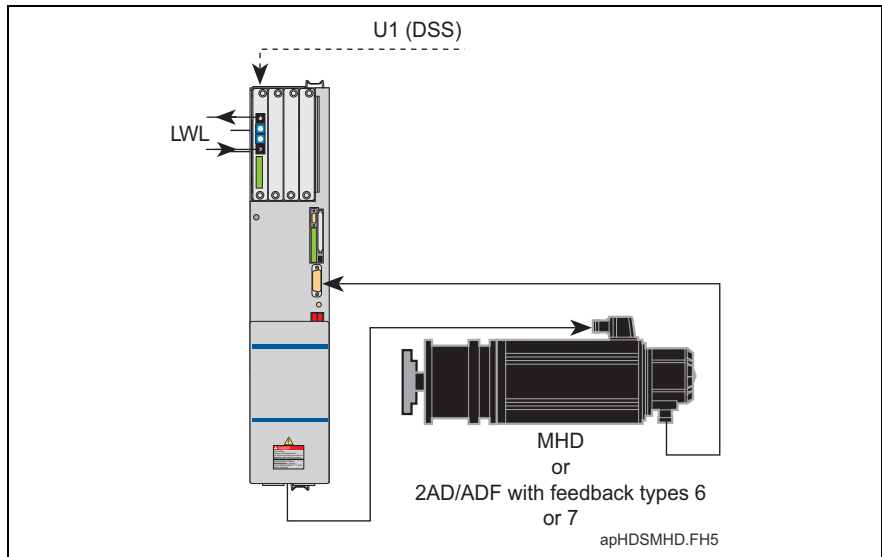

Fig. 3-3: MDD motor with DSF motor feedback at standard interface X4

Sine Encoder

Use plug-in module DLF01.1M to connect plug-in modules:

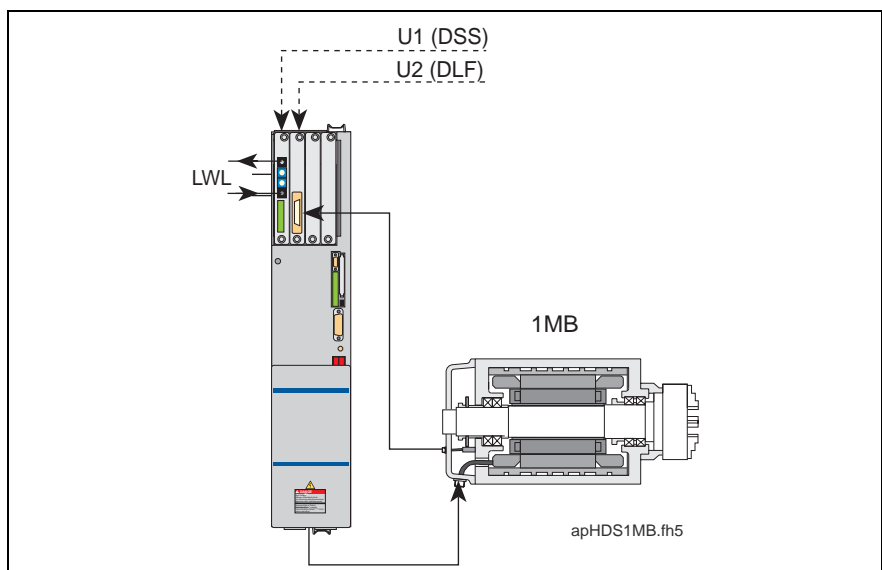

Fig. 3-4: 1MB motor with incremental sine encoder with 1V_{ss} at a DLF01.1M plug-in modules

Gear/wheel Encoder

Use plug-in modules DZF02.1M to connect motor feedback.

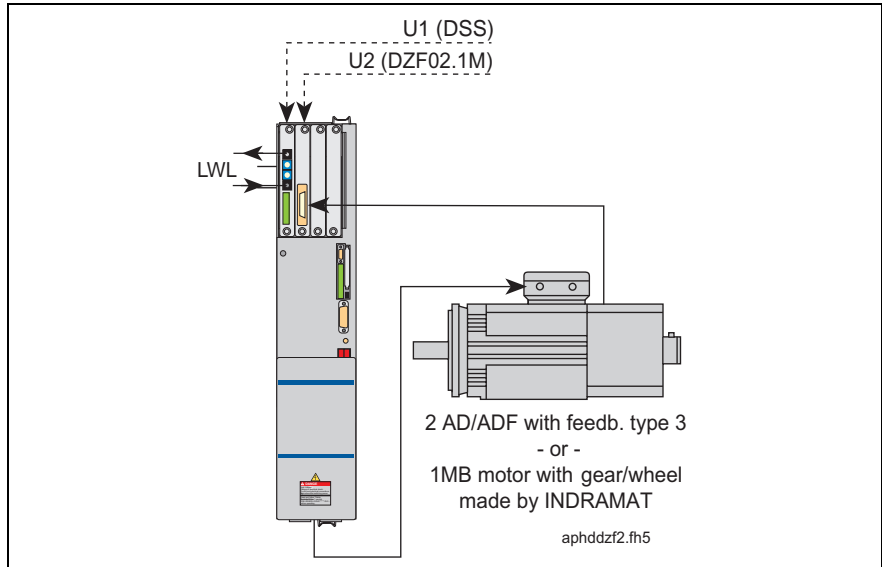

Fig. 3-5: 2AD motor with feedback type 3 (integrated gear/wheel encoder from INDRAMAT) on a DZF02.1M plug-in module

Gear/wheel encoder (Lenord & Bauer, Woelke, VS-Sensorik, Siemens)

Use plug-in module DZF03.1M to connect motor feedback.

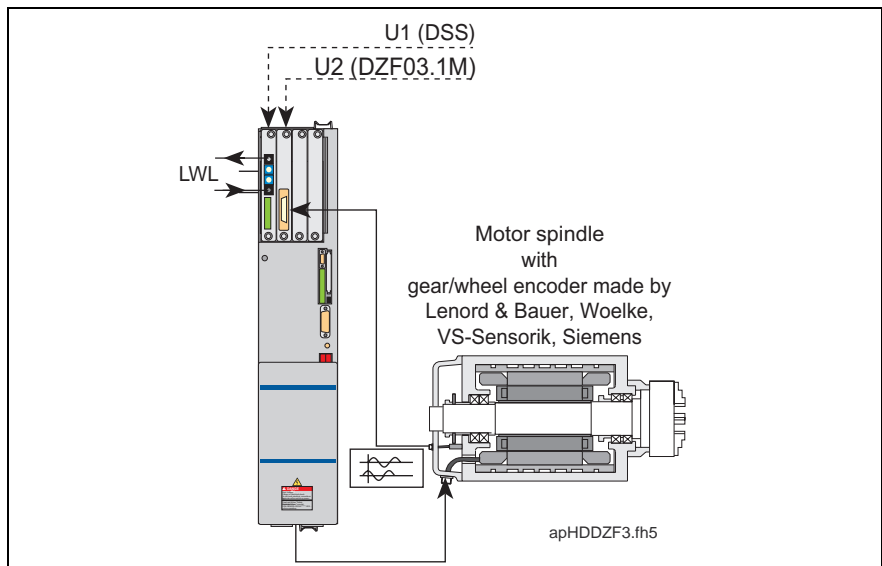

Fig. 3-6: Motor spindle with above-referenced outside supplier encoder on a DZF3.1M plug-in module

Notes

4 Selecting the Functions - Determining Configuration Designations

4.1 Basic Functions

Regardless of the type of motor used, DIAX04 drive controllers offer a series of functions that are always available.

To be able to use these functions, a **separate** plug-in module is not needed, but a configuration designation is nonetheless specified for the controller.

The following **basic functions** are available:

- **Operating modes which are supported:**
 - torque control
 - velocity control
 - position control (in SERCOS-interface only)
 - drive-internal interpolation (in SERCOS interface only)
- extensive diagnostics possibilities
- parametrizable torque/force limits
- current limits
- velocity limits
- **Error-reactions generated by the drive:**
 - best possible standstill "speed command to zero"
 - best possible standstill "torque to zero"
 - best possible standstill "velocity command to zero with ramp and filter"
 - NC reaction with failure
 - emergency stop function
- **Control loop settings**
 - load base values function
 - accel precontrol
 - velocity mix factor
 - velocity precontrol (in SERCOS interface only)
- language switching
- starting lockout
- drive halt
- drive-guided referencing
- evaluation of absolute linear scale
- set absolute dimension
- analog outputs
- oscilloscope function
- probe functions:
 - probe signal actual position value 1/2
 - probe signal time
- modulo function

4.2 Selecting Additional Functions

In addition to its basic functions, the DIAX04 offers a series of additional functions. The basic and additional functions are implemented by the drive firmware which is stored on the software module DSM 02.3-FW.

Additional plug-in modules needed

When selecting the additional functions listed in the following sections, it should be noted that additional plug-in modules are needed.

Maximum number of plug-in modules

Depending on the basic unit, the number of plug-in modules may vary.

HDS04.1	maximum 4 plug-in modules
HDS03.1	maximum 4 plug-in modules
HDS02.1	maximum 3 plug-in modules
HDD02.1	maximum 1 plug-in module/axis

Note: The slot for the command communications interface card is reserved in each basic unit.

Selection conditions

Note the following conditions when selecting the additional functions:

- each plug-in module can only be used for one function
- only one external measuring system can be selected

The use of additional functions depends on, in contrast to the basic functions, the motor feedback used or on the plug-in module needed for the motor feedback connection.

This is why a differentiation will be made in the motor feedbacks throughout the following sections of this documentation.

Motor Feedback: DSF / RSF

If motors with digital servo feedback, e.g., MHD, MKD/MKE, 2AD or ADF, or resolver feedbacks, e.g., MHD or MKD/MKE are used, then the standard motor feedback connection on the controller can be used. The motor feedback connection does not need a plug-in module!

If further measuring systems or additional inputs/outputs are used, then plug-in modules are needed. The allocation is specified in Tab. 4-1.

⇒ Record the plug-in modules needed in the last line of the table!

⇒ Find the combination of needed plug-in modules Tab. 4-2. The corresponding configuration designation is a part of the order data of the DIAX04 controller.

If the required combination is not listed, then this combination is basically not possible. Consult INDRAMAT, if necessary.

Additional requirements:	Plug-in modules							
	DSS 02.1M	DAG 01.2M	DEA 04.2M	DEF 01.1M	DFF 01.1M	DLF 01.1M	DAE 02.1M	DZF 02.1M
Command communications module with SERCOS-interface	X							
Command communications module with analog interface							X	
Slave mode							X	
Digital inputs/outputs (for gear or winding progressions, analog interface)			X					
Spindle feedback ext. measuring system with sine encoder 1V _{ss}						X		
Spindle feedback ext. measuring system with 5V square-wave encoder				X				
Spindle feedback ext. measuring system with GDS encoder					X			
Spindle feedback ext. measuring system with SSI encoder		X						
Spindle feedback ext. measuring system with EnDat encoder		X						
Spindle feedback ext. measuring system with gear/wheel encoder (Indramat)								X
Plug-in modules determined:								

Tab. 4-1: Plug-in modules for additional requirements if standard interface X4 is used on the controller for the motor feedback connection

Configuration designation:	DSS 02.1M	DAG 01.2M	DEA 04.2M	DEF 01.1M	DFF 01.1M	DLF 01.1M	DAE 02.1M	DZF 02.1M	HSM01.1-FW with firmware FWA-DIAX04-...
HS12-01-FW	X								...SHS-02VRS-MS
HS37-01-FW	X							X	...SHS-02VRS-MS
HS56-01-FW	X						X		...SHS-02VRS-MS
HS32-01-FW	X					X			...SHS-02VRS-MS
HS09-01-FW	X				X				...SHS-02VRS-MS
HS76-01-FW	X			X					...SHS-02VRS-MS
HS23-01-FW	X		X						...SHS-02VRS-MS
HS45-01-FW	X	X							...SHS-02VRS-MS
HS38-01-FW	X		X					X	...SHS-02VRS-MS
HS33-01-FW	X		X			X			...SHS-02VRS-MS
HS30-01-FW	X		X		X				...SHS-02VRS-MS
HS78-00-FW	X			X				X	...SHS-02VRS-MS
HS74-02-FW	X	X	X						...SHS-02VRS-MS
HA03-01-FW			X				X		...AHS-02VRS-MS

Tab. 4-2: Configuration designation (motor feedback connection is standard interface X4 on the controller)

Motor Feedback: Sine Encoder

If a motor uses sine feedback with $1V_{ss}$ as the motor feedback, as is the case with 1MB motors, then a plug-in module is needed to connect the motor feedback! The standard motor feedback connection on the controller cannot be used!

If more measuring systems or additional inputs/outputs are to be used, then additional plug-in modules are required. The allocation is outlined in Tab. 4-3.

⇒ record the plug-in modules needed in the last line of the table!

⇒ Locate this combination of plug-in modules in Tab. 4-4. The pertinent configuration designation must be noted on the DIAX04 controller order.

If the combination needed cannot be found in the table, then it is generally not possible. If necessary, consult with INDRAMAT.

Additional requirements:	Plug-in modules							
	DSS 02.1M	DAG 01.2M	DEA 04.2M	DEF 01.1M	DFF 01.1M	DLF 01.1M	DAE 02.1M	DZF 02.1M
Command communications module with SERCOS-interface	X					X		
Command communications module with analog interface						X	X	
Digital inputs/outputs (for gear or winding progressions, analog interface)			X			X		
Plug-in modules determined:								

Tab. 4-3: Plug-in modules for additional requirements, motor feedback connection is DLF01.1M

Configuration designation:	DSS 02.1M	DAG 01.2M	DEA 04.2M	DEF 01.1M	DFF 01.1M	DLF 01.1M	DAE 02.1M	DZF 02.1M	HSM01.1-FW with firmware FWA-DIAX04-...
HS32-01-FW	X					X			...SHS-02VRS-MS
HS33-01-FW	X		X			X			...SHS-02VRS-MS
HA06-01-FW			X			X	X		...AHS-02VRS-MS

Tab. 4-4: Configuration designation (motor feedback connection is DLF01.1M)

Motor Encoder Interface: Gear/ Wheel Encoder made by INDRAMAT

If gear/ wheel encoders from INDRAMAT are used as motor feedbacks, e.g., in 2AD motors (high-resolution motor feedbacks) or 1MB motors, then the motor feedback connection needs a plug-in module! The standard motor feedback connection on the controller cannot be used!

If other measuring systems or additional inputs/outputs are used, then additional plug-in modules are needed. The allocation is outlined in Tab. 4-5.

⇒ record the plug-in modules needed in the last line of the table!

⇒ Locate this combination of plug-in modules in Tab. 4-6. The corresponding configuration designation is a part of the order data of the DIAX04 controller.

If the combination needed cannot be found in the table, then it is generally not possible. If necessary, consult with INDRAMAT.

Additional requirements:	Plug-in modules							
	DSS 02.1M	DAG 01.2M	DEA 04.2M	DEF 01.1M	DFF 01.1M	DLF 01.1M	DAE 02.1M	DZF 02.1M
Command communications module with SERCOS-interface	X							X
Command communications module with analog interface							X	X
Slave mode							X	X
Digital inputs/outputs (for gear or winding progressions, analog interface)			X					X
Spindle feedback ext. measuring system with 5V square-wave encoder				X				X
Spindle feedback ext. measuring system with GDS encoder (standard interface X4)								X
Spindle feedback ext. measuring system with SSI encoder		X						X
Spindle feedback ext. measuring system with EnDat encoder		X						X
Determined Plug-in modules:								

Tab. 4-5: Plug-in modules for additional requirements (motor feedback connection is DZF02.1M)

Configuration designation:	DSS 02.1M	DAG 01.2M	DEA 04.2M	DEF 01.1M	DFF 01.1M	DLF 01.1M	DAE 02.1M	DZF 02.1M	HSM01.1-FW with firmware FWA-DIAX04-...
HS37-01-FW	X							X	...SHS-02VRS-MS
HS26-01-FW	X			X				X	...SHS-02VRS-MS
HS38-01-FW	X		X					X	...SHS-02VRS-MS
HS04-02-FW	X	X						X	...SHS-02VRS-MS
HS36-01-FW	X		X	X				X	...SHS-02VRS-MS
HS03-02-FW	X	X	X					X	...SHS-02VRS-MS
HS19-01-FW	X						X	X	...SHS-02VRS-MS
HA04-01-FW			X				X	X	...AHS-02VRS-MS

Tab. 4-6: Configuration designation (motor feedback connection is DZF02.1M)

Motor Feedback: Gear/Wheel Encoder made by Lenord & Bauer, Woelke, VS-Sensorik, Siemens

If encoders with 1V_{ss} from Lenord & Bauer, Woelke, VS-Sensorik and Siemens are used as motor feedback, e.g., motor spindles with extrinsic motors, then the motor feedback connections needs a plug-in module! The standard motor feedback connection on the controller cannot be used!

If other measuring systems or additional inputs/outputs are used, then additional plug-in modules are needed. The allocation is outlined in Tab. 4-7.

⇒ record the plug-in modules needed in the last line of the table!

⇒ Locate this combination of plug-in modules in Tab. 4-8 The corresponding configuration designation is a part of the order data of the DIAX04 controller.

If the combination needed cannot be found in the table, then it is generally not possible. If necessary, consult with INDRAMAT.

Additional requirements:	Plug-in modules							
	DSS 02.1M	DAG 01.2M	DEA 04.2M	DEF 01.1M	DFF 01.1M	DLF 01.1M	DAE 02.1M	DZF 03.1M
Command communications module with SERCOS-interface	X							X
Command communications module with analog interface							X	X
Digital inputs/outputs (for gear or winding progressions, analog interface)			X					X
Plug-in modules determined:								

Tab. 4-7: Plug-in modules for additional requirements (motor feedback connection is DZF03.1M)

Configuration designation:	DSS 02.1M	DAG 01.2M	DEA 04.2M	DEF 01.1M	DFF 01.1M	DLF 01.1M	DAE 02.1M	DZF 03.1M	HSM01.1-FW with firmware FWA-DIAX04-...
HS79-01-FW	X							X	...SHS-02VRS-MS
HS80-01-FW	X		X					X	...SHS-02VRS-MS
HA05-01-FW			X				X	X	...AHS-02VRS-MS

Tab. 4-8: Configuration designation (motor feedback connection is DZF03.1M)

Directory of Customer Service Locations

Germany

<p><u>Sales region central</u></p> <p>INDRAMAT GmbH D-97816 Lohr am Main Bgm.-Dr.-Nebel-Str. 2 Telefon: 09352/40-0 Telefax: 09352/40-4885</p>	<p><u>Sales region east</u></p> <p>INDRAMAT GmbH D-09120 Chemnitz Beckerstraße 31 Telefon: 0371/3555-0 Telefax: 0371/3555-230</p>	<p><u>Sales region west</u></p> <p>INDRAMAT GmbH D-40849 Ratingen Hansastraße 25 Telefon: 02102/4318-0 Telefax: 02102/41315</p>	<p><u>Sales region north</u></p> <p>INDRAMAT GmbH D-22085 Hamburg Fährhausstraße 11 Telefon: 040/227126-16 Telefax: 040/227126-15</p>
<p><u>Sales region south</u></p> <p>INDRAMAT GmbH D-80339 München Ridlerstraße 75 Telefon: 089/540138-30 Telefax: 089/540138-10</p>	<p><u>Sales region southwest</u></p> <p>INDRAMAT GmbH D-71229 Leonberg Böblinger Straße 25 Telefon: 07152/972-6 Telefax: 07152/972-727</p>		<p><u>INDRAMAT Service-Hotline</u></p> <p>INDRAMAT GmbH Telefon: D-0172/660 040 6 -or- Telefon: D-0171/333 882 6</p>

Fig. 1-4.1: Customer Service Locations in Germany

Europe

<p><u>Austria</u></p> <p>G.L.Rexroth Ges.m.b.H. Geschäftsbereich INDRAMAT A-1140 Wien Hägelingasse 3 Telefon: 1/9852540-400 Telefax: 1/9852540-93</p>	<p><u>Austria</u></p> <p>G.L.Rexroth Ges.m.b.H. Geschäftsbereich INDRAMAT A-4061 Pasching Randlstraße 14 Telefon: 07229/4401-36 Telefax: 07229/4401-80</p>	<p><u>Belgium</u></p> <p>Mannesmann Rexroth N.V.-S.A. Geschäftsbereich INDRAMAT B-1740 Ternat Industrielaan 8 Telefon: 02/5823180 Telefax: 02/5824310</p>	<p><u>Denmark</u></p> <p>BEC Elektronik AS DK-8900 Randers Zinkvej 6 Telefon: 086/447866 Telefax: 086/447160</p>
<p><u>England</u></p> <p>Mannesmann Rexroth Ltd. INDRAMAT Division Cirencester, Glos GL7 1YG 4 Esland Place, Love Lane Telefon: 01285/658671 Telefax: 01285/654991</p>	<p><u>Finnland</u></p> <p>Rexroth Mecman OY SF-01720 Vantaa Riihimiehentie 3 Telefon: 0/848511 Telefax: 0/846387</p>	<p><u>France</u></p> <p>Rexroth - Sigma S.A. Division INDRAMAT F-92632 Gennevilliers Cedex Parc des Barbanniers 4, Place du Village Telefon: 1/41475430 Telefax: 1/47946941</p>	<p><u>France</u></p> <p>Rexroth - Sigma S.A. Division INDRAMAT F-69634 Venissieux - Cx 91, Bd 1 Joliot Curie Telefon: 78785256 Telefax: 78785231</p>
<p><u>France</u></p> <p>Rexroth - Sigma S.A. Division INDRAMAT F-31100 Toulouse 270, Avenue de l'ardenne Telefon: 61499519 Telefax: 61310041</p>	<p><u>Italy</u></p> <p>Rexroth S.p.A. Divisione INDRAMAT I-20063 Cernusco S/N.MI Via G. Di Vittoria, 1 Telefon: 02/92365-270 Telefax: 02/92108069</p>	<p><u>Italy</u></p> <p>Rexroth S.p.A. Divisione INDRAMAT Via Borgomanero, 11 I-10145 Torino Telefon: 011/7712230 Telefax: 011/7710190</p>	<p><u>Netherlands</u></p> <p>Hydraudyne Hydrauliek B.V. Kruisbroeksestraat 1a P.O. Box 32 NL-5280 AA Boxtel Telefon: 04116/51951 Telefax: 04116/51483</p>
<p><u>Spain</u></p> <p>Rexroth S.A. Centro Industrial Santiago Obradors s/n E-08130 Santa Perpetua de Mogoda (Barcelona) Telefon: 03/718 68 51 Telex: 591 81 Telefax: 03/718 98 62</p>	<p><u>Spain</u></p> <p>Goimendi S.A. División Indramat Jolastokieta (Herrera) Apartado 11 37 San Sebastian, 20017 Telefon: 043/40 01 63 Telex: 361 72 Telefax: 043/39 93 95</p>	<p><u>Sweden</u></p> <p>AB Rexroth Mecman INDRAMAT Division Varuvägen 7 S-125 81 Stockholm Telefon: 08/727 92 00 Telefax: 08/64 73 277</p>	<p><u>Switzerland</u></p> <p>Rexroth SA Département INDRAMAT Chemin de l'Ecole 6 CH-1036 Sullens Telefon: 021/731 43 77 Telefax: 021/731 46 78</p>
<p><u>Switzerland</u></p> <p>Rexroth AG Geschäftsbereich INDRAMAT Gewerbstraße 3 CH-8500 Frauenfeld Telefon: 052/720 21 00 Telefax: 052/720 21 11</p>	<p><u>Russia</u></p> <p>Tschudhenko E.B. Arsenia 22 153000 Ivanovo Rußland Telefon: 093/22 39 633</p>		

Fig. 1-4.2: European Customer Service Locations without Germany

Outside of Europe

<p>Argentina</p> <p>Mannesmann Rexroth S.A.I.C. Division INDRAMAT Acassusso 48 41/7 1605 Munro (Buenos Aires) Argentina Telefon: 01/756 01 40 01/756 02 40 Telex: 262 66 rexro ar Telefax: 01/756 01 36</p>	<p>Argentina</p> <p>Nakase Asesoramiento Tecnico Diaz Velez 2929 1636 Olivos (Provincia de Buenos Aires) Argentina Argentina Telefon 01/790 52 30</p>	<p>Australia</p> <p>Australian Industrial Machinery Services Pty. Ltd. Unit 3/45 Horne ST Campbellfield VIC 2061 Australia Telefon: 03/93 59 0228 Telefax: 03/93 59 02886</p>	<p>Brazil</p> <p>Mannesmann Rexroth Automação Ltda. Divisão INDRAMAT Rua Georg Rexroth, 609 Vila Padre Anchieta BR-09.951-250 Diadema-SP Caixa Postal 377 BR-09.901-970 Diadema-SP Telefon: 011/745 90 65 011/745 90 70 Telefax: 011/745 90 50</p>
<p>Canada</p> <p>Basic Technologies Corporation Burlington Division 3426 Mainway Drive Burlington, Ontario Canada L7M 1A8 Telefon: 905/335-55 11 Telefax: 905/335-41 84</p>	<p>China</p> <p>Rexroth (China) Ltd. Shanghai Office Room 206 Shanghai Intern. Trade Centre 2200 Yanan Xi Lu Shanghai 200335 P.R. China Telefon: 021/627 55 333 Telefax: 021/627 55 666</p>	<p>China</p> <p>Rexroth (China) Ltd. Shanghai Parts & Service Centre 199 Wu Cao Road, Hua Cao Minhang District Shanghai 201 103 P.R. China Telefon: 021/622 00 058 Telefax: 021/622 00 068</p>	<p>China</p> <p>Rexroth (China) Ltd. 1430 China World Trade Centre 1, Jianguomenwai Avenue Beijing 100004 P.R. China Telefon: 010/50 50 380 Telefax: 010/50 50 379</p>
<p>China</p> <p>Rexroth (China) Ltd. A-5F., 123 Lian Shan Street Sha He Kou District Dalian 116 023 P.R. China Telefon: 0411/46 78 930 Telefax: 0411/46 78 932</p>	<p>Hongkong</p> <p>Rexroth (China) Ltd. 19 Cheung Shun Street 1st Floor, Cheung Sha Wan, Kowloon, Hongkong Telefon: 741 13 51/-54 und 741 14 30 Telex: 3346 17 GL REX HX Telefax: 786 40 19 786 07 33</p>	<p>India</p> <p>Mannesmann Rexroth (India) Ltd. INDRAMAT Division Plot. 96, Phase III Peenya Industrial Area Bangalore - 560058 Telefon: 80/839 21 01 80/839 73 74 Telex: 845 5028 RexB Telefax: 80/839 43 45</p>	<p>Japan</p> <p>Rexroth Co., Ltd. INDRAMAT Division I.R. Building Nakamachidai 4-26-44 Tsuzuki-ku, Yokohama 226 Japan Telefon: 045/942-72 10 Telefax: 045/942-03 41</p>
<p>Korea</p> <p>Rexroth-Seki Co Ltd. 1500-12 Da-Dae-Dong Saha-Gu, Pusan, 604-050 Telefon: 051/264 90 01 Telefax: 051/264 90 10</p>	<p>Korea</p> <p>Seo Chang Corporation Ltd. Room 903, Jail Building 44-35 Yoido-Dong Youngdeungpo-Ku Seoul, Korea Telefon: 02/780-82 07 -9 Telefax: 02/784-54 08</p>	<p>Mexico</p> <p>Motorización y Diseño de Controles, S.A. de C.V. Av. Dr. Gustavo Baz No. 288 Col. Parque Industrial la loma Apartado Postal No. 318 54060 Tlalnepantla Estado de Mexico Telefon: 5/397 86 44 Telefax: 5/398 98 88</p>	
<p>USA</p> <p>Rexroth Corporation INDRAMAT Division 5150 Prairie Stone Parkway Hoffman Estates, Illinois 60192 Telefon: 847/645-36 00 Telefax: 857/645-62 01</p>	<p>USA</p> <p>Rexroth Corporation INDRAMAT Division 2110 Austin Avenue Rochester Hills, Michigan 48309 Telefon: 810/853-82 90 Telefax: 810/853-82 90</p>		

Fig. 1-4.3: Customer Service Locations outside of Europe

Notes

