

# ISO 15552, series CCL-IS

- ISO 15552
- Ø 25-125 mm
- Ports G 1/8 G 1/4 G 3/8 G 1/2
- double-acting
- with magnetic piston
- Cushioning pneumatically adjustable
- Piston rod External thread
- ATEX optional
- suitable for use in food processing
- Optionally heat-resistant

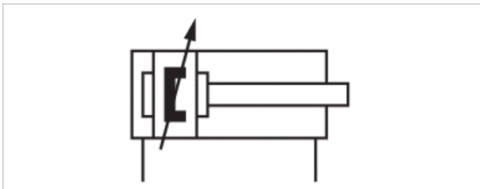

Standards	ISO 15552
Certificates	ATEX optional
Compressed air connection	Internal thread
Working pressure min./max.	1,5 ... 10 bar
Ambient temperature min./max.	-20 ... 80 °C
Medium temperature min./max.	-20 ... 80 °C
Medium	Compressed air
Max. particle size	50 µm
Oil content of compressed air	0 ... 5 mg/m <sup>3</sup>
Pressure for determining piston forces	6.3 bar



## Technical data

Piston Ø Piston rod thread Ports Piston rod Ø	25 mm M10x1,25 G 1/8 12 mm	32 mm M10x1,25 G 1/8 12 mm	40 mm M12x1,25 G 1/4 16 mm	50 mm M16x1,5 G 1/4 20 mm	63 mm M16x1,5 G 3/8 20 mm	80 mm M20x1,5 G 3/8 25 mm
Stroke 25	R480671114	R480060005	R480060018	R480060026	R480060036	R480060060
50	R480671115	R480058830	R480059528	R480060027	R480058890	R480060061
80	R480671116	R480060006	R480060019	R480060028	R480060037	R480060063
100	R480671117	R480059075	R480060020	R480060029	R480060038	R480060064
125	R480671118	R480060007	R480060021	R480060030	R480060039	R480059699
160	R480671119	R480060008	R480059526	R480060031	R480060040	R480060065
200	R480671120	R480060009	R480060022	R480060032	R480060041	R480059532
250	R480671121	R480060010	R480060023	R480060033	R480060043	R480060066
320	R480671122	R480060011	R480060024	R480060034	R480060042	R480060067
400	R480671123	R480060012	R480059529	R480058941	R480060044	R480060068
500	R480671124	R480060013	R480060025	R480060035	R480060045	R480060069

Piston Ø Piston rod thread Ports Piston rod Ø	100 mm M20x1,5 G 1/2 25 mm	125 mm M27x2 G 1/2 32 mm
Stroke 25	R480060070	R480060080
50	R480060071	R480060081
80	R480060072	R480060082
100	R480060073	R480060083
125	R480060074	R480060084
160	R480060075	R480060085
200	R480060076	R480060086
250	R480058909	R480060087
320	R480060077	R480140649
400	R480060078	R480060089
500	R480060079	R480060091

## Technical data

Piston Ø	25 mm	32 mm	40 mm	50 mm	63 mm	80 mm	100 mm
Retracting piston force	260 N	435 N	665 N	1039 N	1766 N	2857 N	4639 N
Extracting piston force	309 N	507 N	792 N	1237 N	1964 N	3167 N	4948 N
Cushioning length	11 mm	16,5 mm	19 mm	17 mm	16,5 mm	19,5 mm	19,5 mm
Cushioning energy	2,3 J	4,8 J	9 J	15 J	27 J	54 J	88 J
Weight 0 mm stroke	0,33 kg	0,61 kg	0,92 kg	1,37 kg	1,77 kg	3,23 kg	4,42 kg
Weight +10 mm stroke	0,025 kg	0,036 kg	0,049 kg	0,065 kg	0,076 kg	0,081 kg	0,133 kg
Stroke max.	1500 mm	1600 mm	1900 mm	2100 mm	2500 mm	2800 mm	2800 mm

Piston Ø	125 mm
Retracting piston force	7224 N
Extracting piston force	7731 N
Cushioning length	22 mm
Cushioning energy	140 J
Weight 0 mm stroke	6,69 kg
Weight +10 mm stroke	0,127 kg
Stroke max.	2750 mm

## Technical information

The pressure dew point must be at least 15 °C under ambient and medium temperature and may not exceed 3 °C .

Ø25 not according to ISO 15552

The material for heat-resistant scraper and seal variants (ambient temperature: -10 °C ... 120 °C) is PTFE.

Further options can be generated in the Internet configurator.

ATEX-certified cylinders with identification II 2G Ex h IIC T4 Gb / II 2D Ex h IIC T135°C Db\_X can be generated in the Internet configurator.

The operating temperature range for ATEX-certified cylinders is -20°C ... 60°C.

Ø25 not according to ISO 15552

## Technical information

Material	
Cylinder tube	Aluminum, anodized
Piston rod	Stainless steel
Front cover	Aluminum, anodized
End cover	Aluminum, anodized
Scraper	Polyester
Tie-rods	Stainless steel
Grease	AGF (NSF-H1)

# Dimensions

## Dimensions

**Ø 25 - 63**

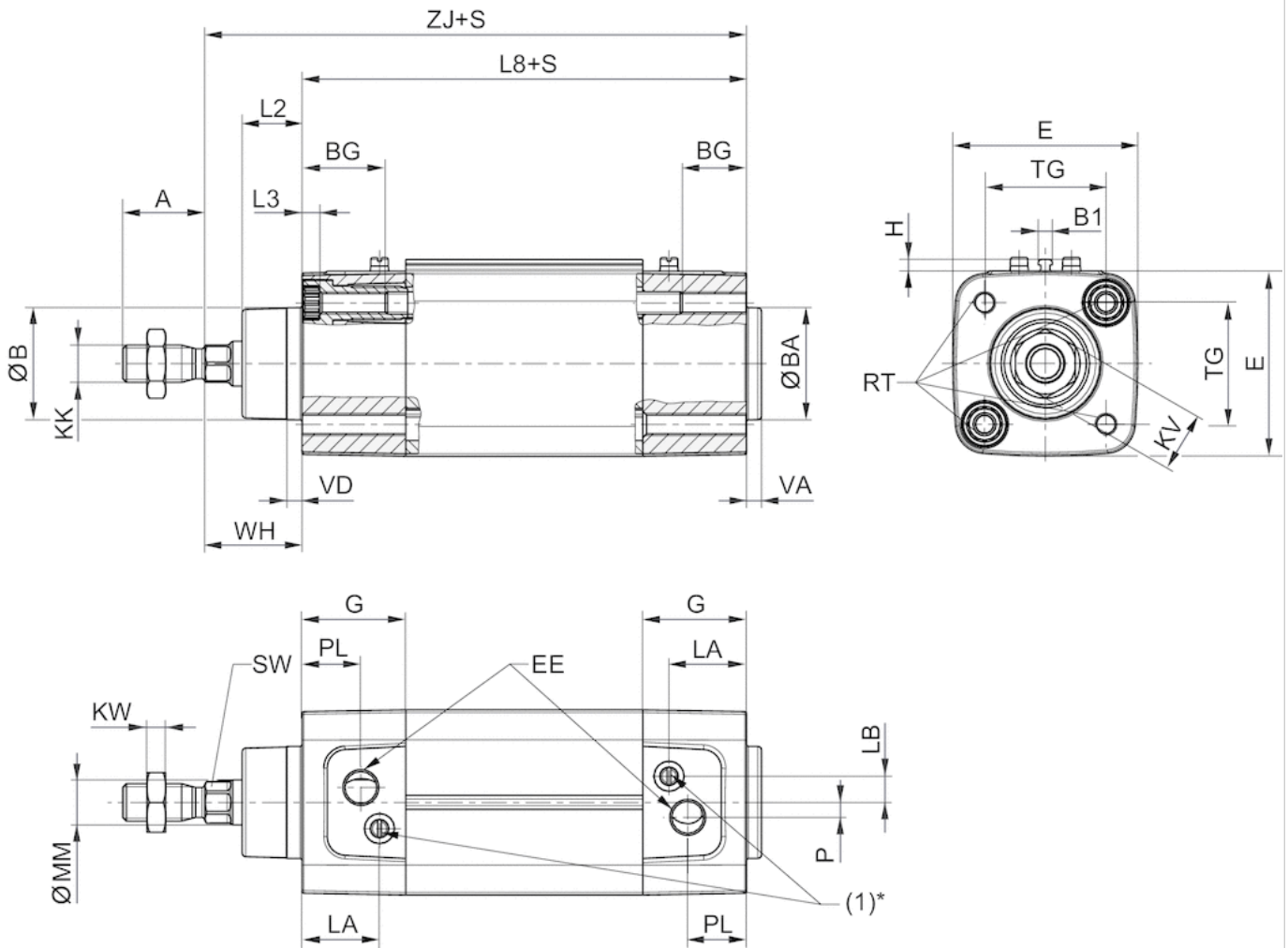

S = stroke

\* The flow control screw (1) only has a function in cylinders with adjustable cushioning.

Ø80 - 125

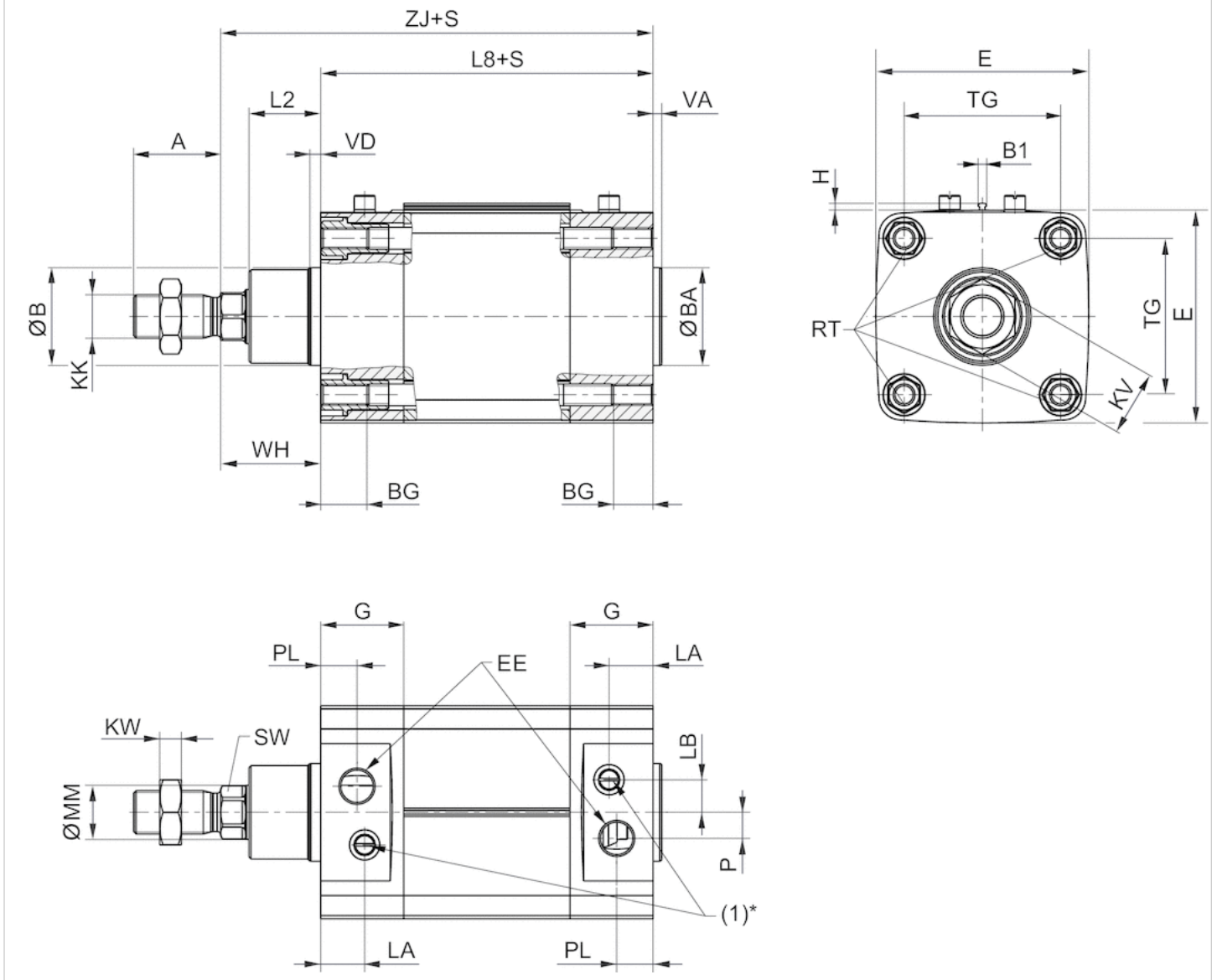

S = stroke

\* The flow control screw (1) only has a function in cylinders with adjustable cushioning.

## Dimensions

Piston Ø	A	ØB / ØBA d11	B1	BG mm	E	EE	G	H	KK	KV	KW	L2	L3 max.
25 mm	22	24	3.8	12.5	40.5	G1/8	20	3.1	M10x1,25	16	5	16	5
32 mm	22	30	3.8	16	49.5	G1/8	27.75	3.1	M10x1,25	16	5	16	5
40 mm	24	35	3.8	16	57.5	G1/4	33.25	3.1	M12x1,25	18	6	18.25	5
50 mm	32	40	3.8	16	69.5	G1/4	31	3.1	M16x1,5	24	8	25	5
63 mm	32	45	3.8	16	79.5	G3/8	38,25	3.1	M16x1,5	24	8	25	5
80 mm	40	45	3.8	17	98	G3/8	38,25	3.1	M20x1,5	30	10	33	-
100 mm	40	55	3.8	17	115,5	G1/2	42,25	3.1	M20x1,5	30	10	36	-
125 mm	54	60	3.8	20	145	G1/2	54	3.1	M27x2	41	13,5	45	-

Piston Ø	L8	LA	LB	MM f8	P	PL	RT	SW	TG	VA	VD	WH	ZJ
25 mm	74 ±0,4	13.5	6	12	4.5	10.3	M5	10	26 ±0,4	-	-	24 ±1,4	98
32 mm	94 ±0,4	20.75	7	12	4	15.75	M6	10	32,5 ±0,5	4	4	26 ±1,4	120
40 mm	105 ±0,7	22.75	8	16	5	16.75	M6	13	38 ±0,5	4	5	30 ±1,4	135
50 mm	106 ±0,7	20	12	20	7,7	16	M8	17	46,5 ±0,6	4	5	37 ±1,4	143
63 mm	121 ±0,8	27,25	11	20	11	19,25	M8	17	56,5 ±0,7	4	5	37 ±1,8	158
80 mm	128 ±0,8	20,25	15	25	12	16,75	M10	22	72 ±0,7	4	5	46 ±1,8	174
100 mm	138 ±1	24,25	14	25	17	19,25	M10	22	89 ±0,7	4	5	51 ±1,8	189
125 mm	160 ±1	25,5	4	32	27,5	20	M12	27	110 ±1,1	6	6	65 ±2,2	225

## Diagrams

### Cushioning diagram

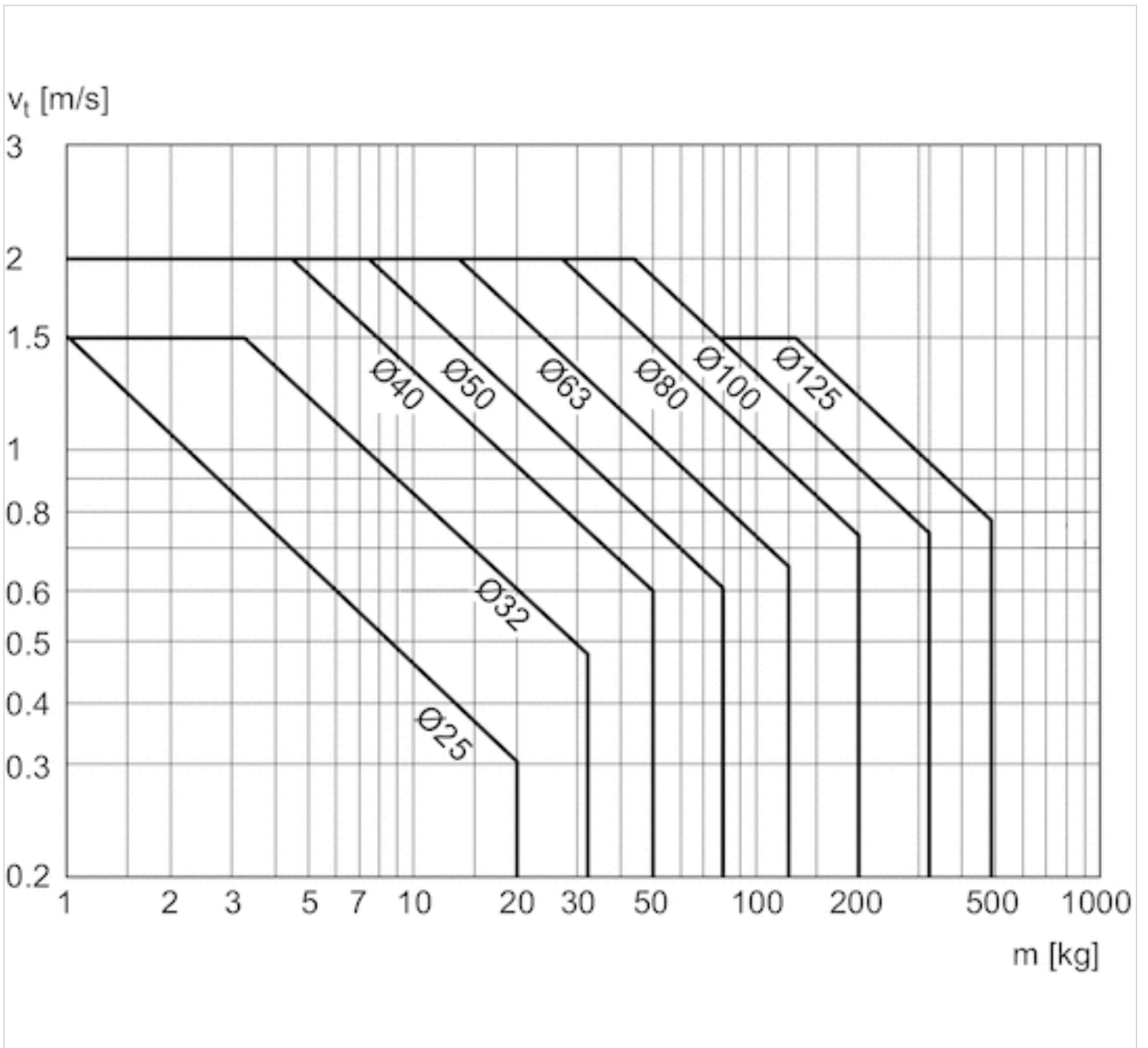

V = velocity [m/s]  
m = mass

## Accessories overview

### Overview drawing

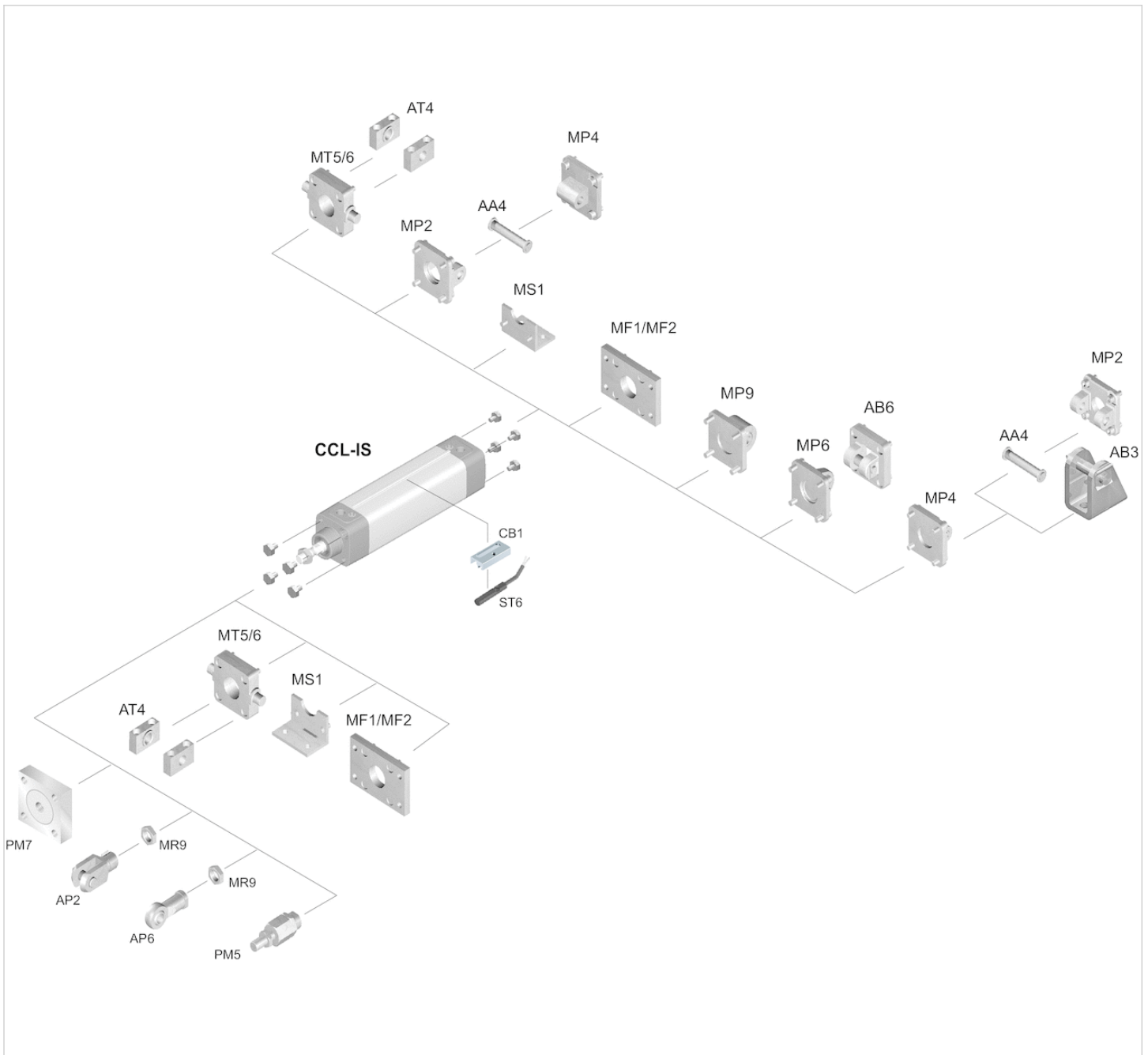

**NOTE:**

This overview drawing is only for orientation to indicate where the various accessory parts can be fastened to the cylinder. The illustration has been simplified for this purpose. It is thus not possible to derive the dimensions from this overview.

# Efficient pneumatic solutions, our program: cylinders and drives, valves and valve systems, air supply management



Visit us: [Emerson.com/Aventics](https://www.emerson.com/Aventics)

Your local contact: [Emerson.com/contactus](https://www.emerson.com/contactus)



Emerson.com



[Facebook.com/EmersonAutomationSolutions](https://www.facebook.com/EmersonAutomationSolutions)



[LinkedIn.com/company/Emerson-Automation-Solutions](https://www.linkedin.com/company/Emerson-Automation-Solutions)



[Twitter.com/EMR\\_Automation](https://twitter.com/EMR_Automation)

An example configuration is depicted on the title page. The delivered product may thus vary from that in the illustration. Subject to change. This Document, as well as the data, specifications and other information set forth in it, are the exclusive property of AVENTICS GmbH. It may not be reproduced or given to third parties without its consent. Only use the AVENTICS products shown in industrial applications. Read the product documentation completely and carefully before using the product. Observe the applicable regulations and laws of the respective country. When integrating the product into applications, note the system manufacturer's specifications for safe use of the product. The data specified only serve to describe the product. No statements concerning a certain condition or suitability for a certain application can be derived from our information. The information given does not release the user from the obligation of own judgement and verification. It must be remembered that the products are subject to a natural process of wear and aging.

The Emerson logo is a trademark and service mark of Emerson Electric Co. Brand logotype are registered trademarks of one of the Emerson family of companies. All other marks are the property of their respective owners. © 2020 Emerson Electric Co. All rights reserved.  
2020-12



## CONSIDER IT SOLVED™